



Venom Turbomatic 400 Nozzle

The Venom Turbomatic 400 Hose Nozzle automatically adjusts the flow rate to compensate for pressure fluctuations, minimising recoil, and maintaining optimum performance.

FEATURES

Hard Anodized Aluminium.

Automatic, constant pressure, variable flow, flow does not change with pattern.

Simple to operate (¼ turn from straight stream to fog).

Raised identification lug on the bumper to assist in low visibility operations.

Easy to service and repair.

Compatible with foam making equipment.

Technical Specification	
Weight	1.8kg
Materials	Body - Hard Anodized Aluminium, Handle & Valve - ABS Bumper - Rubber
Max Sealing Test Pressure	24 bar, factory tested 30 bar
Max Strength Test Pressure	24 bar, factory tested 30 bar
Max Use Working Pressure	16 bar
Advised Working Pressure	6 bar
Minimum Operational Pressure	3 bar
Max Fog Angle	130°
Throw Range	40m at 6 bar
Flow Range	40 - 400 litres/min, automatic
Coupling Options	Instantaneous BS336 BSP, NST, Guillemin / DSP Rotta & Gost and many more

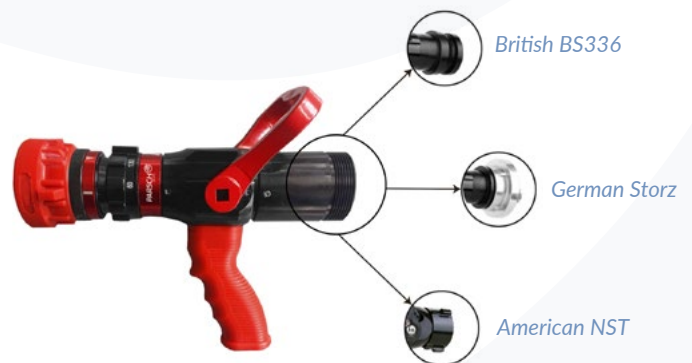
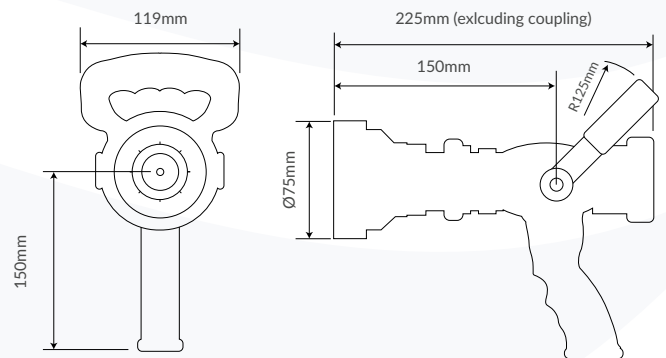

VENOM TURBOMATIC 400 NOZZLE OPERATION

KEY PARTS :

- 1 **Valve Close:**
Push the handle forward
- 2 **Valve Open:**
Push the handle backward
- 3 **SS-FOG Pattern:**
Twist the rubber bumper



NOZZLE PERFORMANCE

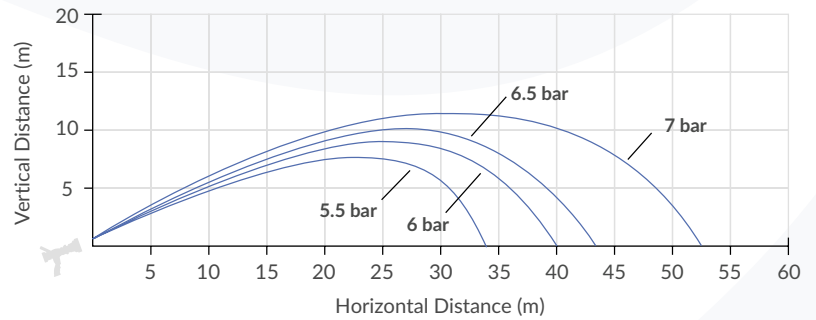

Testing Environment: 30° throw angle, wind speed ≤2m/s